

A perfect combination of technology, quality and beauty.

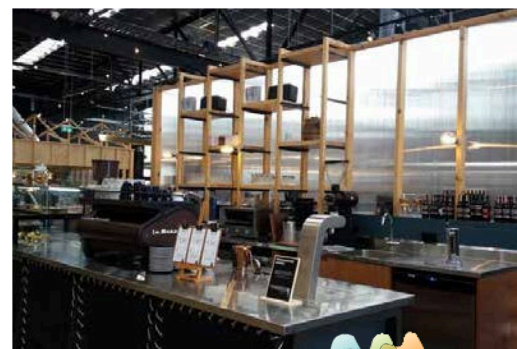

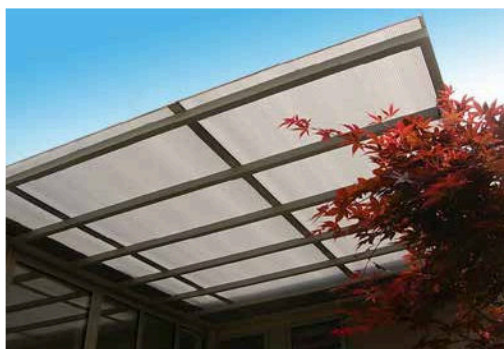
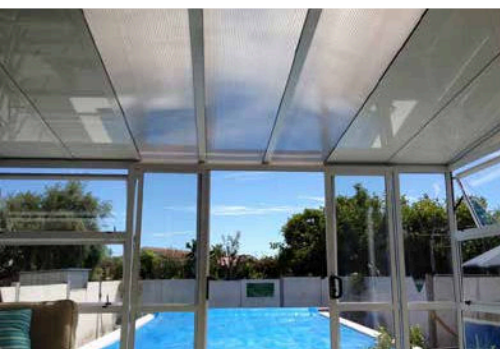

Laserlite® 2000+ Twinwall is a premium multi-wall polycarbonate sheet, with the most advanced and proven technology to date. Laserlite® 2000+ Twinwall polycarbonate sheet is an ideal combination, offering a lightweight glazing panel with excellent impact resistance and has an industry leading 15 year warranty against loss of light transmission.

Manufactured by PT Impack Pratama Industri TBK, a global leader in the design and manufacture of thermoformed polymers, Laserlite® 2000+ Twinwall polycarbonate sheet offers superior clarity, durability and unmatched design flexibility and structural integrity that surpasses other glazing material.

Laserlite® 2000+ Twinwall is the first choice for almost any demanding glazing application. Offering excellent thermal and acoustical properties as well as being aesthetically pleasing, Laserlite® 2000+ Twinwall will meet most architectural requirements and is available in a range of attractive colour tint options.

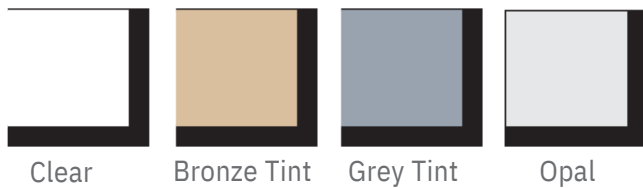

Laserlite 2000+ Twinwall is available in thicknesses of 6mm and 8mm, in 1.220m widths and 5.8m lengths.

Stock lengths are cut from these to suit each individual project requirement.

Advantages of Laserlite® 2000+ Twinwall Polycarbonate

- NZBC Fire group 1-S
- Reduces heat without sacrificing light
- Absorbs almost 100% of sunlight UV radiation
- 250 times stronger than glass and 20 times stronger than acrylic
- Very light, very strong and virtually unbreakable
- Capable of withstanding temperature fluctuations from -20°C to 120°C
- 15 year limited warranty against loss of light transmission

Light & Heat Transmission

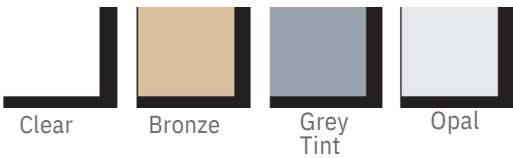

	Clear	Bronze	Grey Tint	Opal
Light Transmission %	86%	25%	11%	18%
Heat Transmission % ‡	76%	30%	24%	29%
Shading Co-efficient	0.90	0.59	0.54	0.39
Solar Heat Gain Co-efficient	0.79	0.52	0.47	0.34

*Above data applies for Laserlite® 2000+ Twinwall 8mm only

Light Transmission (LT)

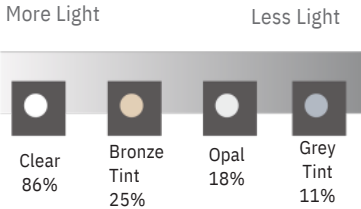

Light Transmission (LT): % of visible light transmission (400-700nm) that passes through the sheet. The lower the figure the less light passes through the sheet.

Heat Transmission (HT)

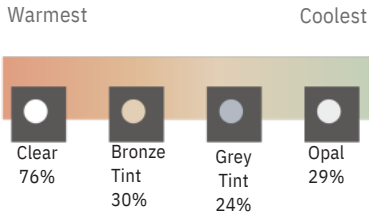

Heat Transmission (HT): % of total solar radiation transmission (300-2800nm). This value describes the ability of the sheet to conduct heat. The lower the figure the greater the heat resistance, the cooler it is under the sheet.

Shading Co-efficient Ratio (SC)



Shading Co-efficient (SC): A ratio of the warming effect of the sun's rays through a sheet divided by the sun's warming effect through 3mm float glass (300-2500nm). The lower the figure the cooler it is under the sheet.

Solar Heat Gain Co-efficient (SHGC)



Solar Heat Gain Coefficient (SHGC): Total solar energy transmitted or absorbed and re-radiated under the sheet (300-2500nm). The lower the figure the cooler it is under the sheet.

How it Works

Being a multiwall product Laserlite® 2000+ Twinwall offers reduced thermal buildup under the sheet as compared to single skin products. Whilst allowing sufficient light transmittance Laserlite® 2000+ Twinwall should be considered where heat reduction is a design consideration.

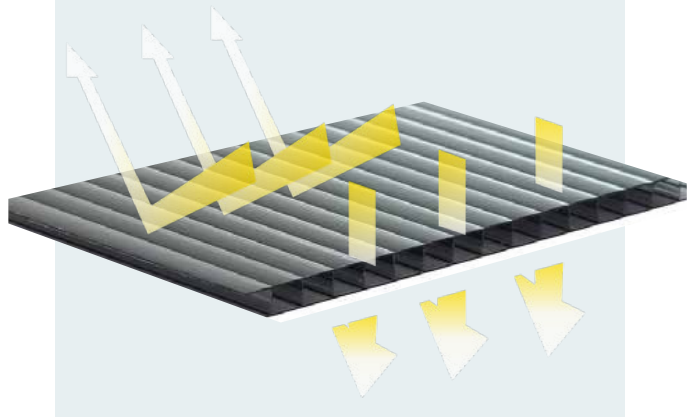

NZBC Fire Group 1-S Rating

Extensively tested using the full scale ISO 9705 room test. This extensive testing utilises a gas burner exposing the sheeting to 100kw fire for 10 minutes, and then an increase to 300kw for a further 10 minutes. Laserlite® Twinwall Polycarbonate achieves a NZBC 1-S Rating as flashover is not reached.

Comparison to Glass

Based on 6mm clear Laserlite 2000+ Twinwall vs 8mm clear standard glass

IMPACT RESISTANCE

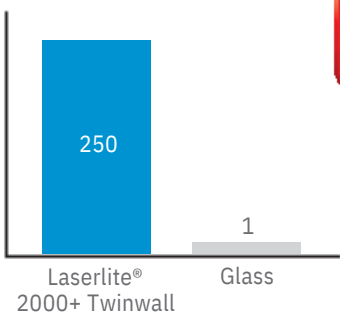

WEIGHT (per m2)

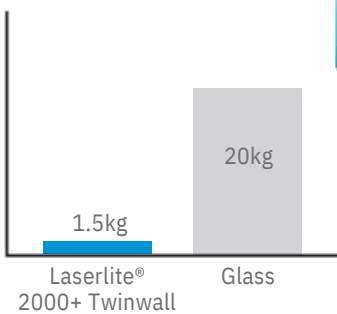

UV PROTECTION

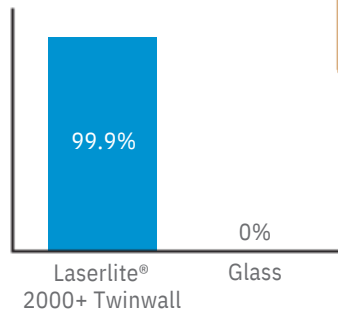

Technical Data

PRODUCT OVERVIEW

Laserlite Twinwall is a twinwall hollow structured flat lightweight polycarbonate glazing sheet

Thickness	Width (metres)	Length (metres)	Area Weight (kg/m ²)	U-Value (W/m ² °C)
6 mm	1.220 m	1.8 to 5.8m	1.3 kgm ²	3.5
8 mm	1.220 m	1.8 to 5.8m	1.5 kgm ²	3.3
10 mm*	1.050 m	1.8 to 5.8m	1.7 kgm ²	2.9

*10mm is available in Clear only.

* Other sizes are available upon request, subjected to minimum order quantity

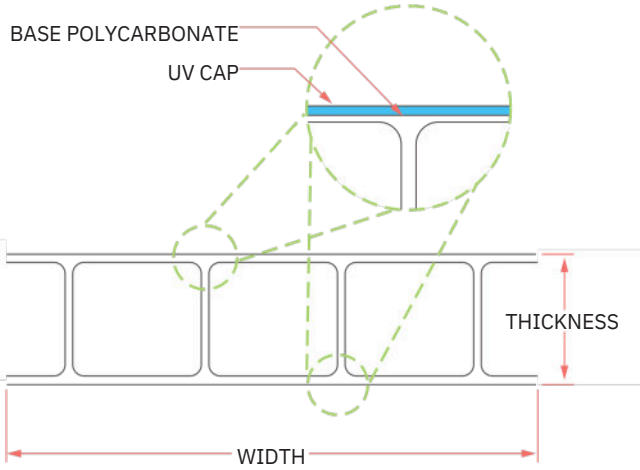

CHEMICAL RESISTANCE

Laserlite Twinwall may be affected by certain substances that may cause surface cracks. For general guidance, Laserlite Twinwall is affected by: Benzene, Petrol, Ketones, Acetone, Phenols, Chlorinated and aromatic Hydrocarbons and petroleum based paints, abrasive cleaners and solvents.

For more information please contact Supreme Plastic Roofing.



TYPICAL PROPERTIES

Laserlite® Twinwall prevents the transmission of more than 99.9% of harmful UV radiation and is suitable for use in high and very high wind zones.

Laserlite Twinwall is BRANZ fire tested meeting NZBC fire group classification 1-S changes to the building code clauses c1 - c6.



TYPICAL PROPERTIES

Property	Method	Unit	Value
MECHANICAL			
Tensile Strength at Yield	ASTM D638	MPa	64
Elongation at break	ASTM D638	%	90
Flexural Strength	ASTM D790	MPa	93
Impact falling weight	ASTM D5420	J	40
THERMAL			
Coefficient of thermal expansion	ISO 6946	mm/m/°C	0.065
Service temperature	-	°C	-20 to 120
FLAMMABILITY			
Horizontal burn	UL94	mm	<2.54
Vertical burn	UL94	-	V1 Class
Ignition temperature, flash	ASTM D1929	°C	440

Technical Data

WIND LOAD

For high and very high wind zones it is necessary to decrease the purlin spans, please refer to the below graph for recommendations.

Four Sides Clamped Flat Glazing

Thickness (mm)	Wind Load (Kg/m ²)	Centre to Centre Distance (mm) between shorter span according to a:b* ratio		
		1:1	1:1.5	1:>1.5
6	50	900	700	500
	80	700	500	350
	100	500	400	-
	120	40	300	-
8	50	1,150	900	600
	80	1,000	800	480
	100	900	650	450
	120	750	600	-
10	50	1,250	1,000	750
	80	1,200	900	550
	120	950	700	450

*a = represents the center to center distance of glazing profiles on the short glazing side i.e. width of the sheet.

*b = represents the center to center distance of glazing profiles on the long glazing side i.e. Length of sheet.

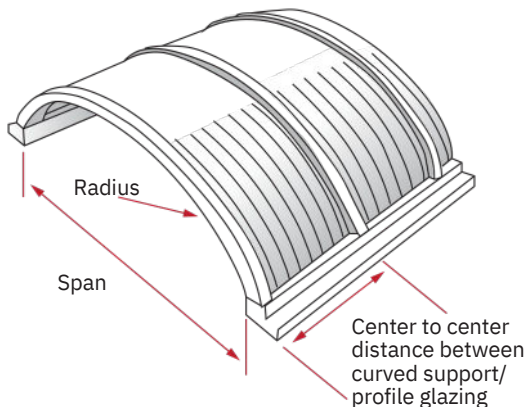
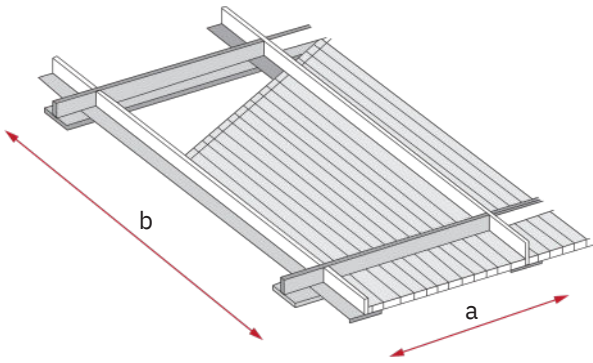

Two Sides Clamped Arched Glazing

Thickness (mm)	Arched-Curvature Radius (mm)	Centre to Centre Distance (mm) between supporting arches according to wind loads (Kg/m ²)			
		50	80	100	120
6	1,050	2,000	1,730	1,420	1,020
	1,500	1,470	1,090	890	660
	1,800	1,140	860	690	580
	2,200	810	690	-	-
	2,800	500	350	-	-
	4,000	500	350	-	-
8	1,400	1,650	1,450	1,320	1,170
	1,800	1,420	1,270	1,070	890
	2,200	1,090	890	710	600
	2,800	840	620	450	-
	4,000	600	500	-	-
	6,000	570	480	-	-
10	1,750	69	1,420	1,170	1,020
	2,200	88	960	810	660
	2,800	110	650	600	550
	4,000	600	500	-	-
	6,000	236	520	500	420

PRODUCT PERFORMANCE WARRANTY

Laserlite® Twinwall UV cap is co-extruded on both sides [UV2], this UV cap provides excellent protection against degradation and discoloration caused by UV radiation after years of exposure [evaluated according to ASTM D1925] the sheet shall not be ruptured due to loss of impact strength as a result of weathering or as a result of hail measuring up to 25mm in diameter attaining a velocity of up to 21 m/s.

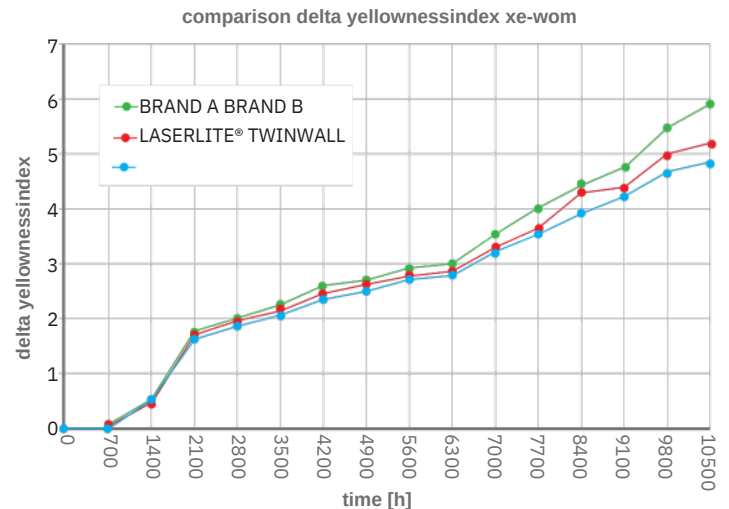

Information contained herein is intended only for evaluation by technically skilled persons, with any use thereof to be at their discretion. While we believe such information is reliable, Supreme Plastic Roofing or its agents shall have no liability for result obtained or damages resulting from such use. Nothing in this document should be construed as a warranty or guarantee by Supreme Plastic Roofing. The only applicable warranty will be those issued in writing by Supreme Plastic Roofing based on the product and usage environment specified.

1. Measure and cut the Aluminium joiner to the required length allowing at least 30mm overhang beyond the rafter for the end cap. Pre-drill your fixing holes through the center of the joiner while still on the ground at 300-400mm, make sure to get these centered as best you can. With the fixings supplied, attach the bottom piece of the joiner to your rafter.



2. If you have purlins OR intermediate rafters run the anti noise tape along all of these now with the sticky side applied to the rafter. Note, you do NOT need to apply noise tape to the rafter that the joiner is being fixed to.



3. Once in place, measure and cut the Acrylic OR twin wall to size (if required), allow for 3mm expansion down each side of the joiner. If you have the materials but have not yet worked out your sheet widths, you will need to take off 26mm from your rafter centers for the joiner gain (13mm each side) This 13mm per side allows for expansion. *For example, 640mm rafter centers less 26mm = 614mm sheet width. If using Twin wall this is when you will apply the dust tape along both open ends of the flutes.*

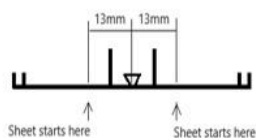

4. Slide the Butterfly Rubber into the 4 channels on the top and bottom pieces of the aluminum joiner. If you are using a joiner for an outside edge, you do not need to run butterfly rubber down the last outside channels, leave these free. This is where you will run the edge strip once the top piece of the joiner has been clicked into place.



5. Before placing the sheets into position, remove 100mm of the top and bottom film on the sides which will be going into the joiner. Place the sheets into position ensure you have a 3mm gap from the inside of the Aluminium on both sides. Place the top piece of the Aluminium joiner into the base of the bottom piece and click into place. You will need to apply some force to fully lock the top piece in, you can use a rubber mallet or a hammer and a piece of timber. Please note that you must place sheets on both sides of the joiner before locking the top piece down. We would recommend for high wind areas you put a fixing through the center of the joiner once clicked together, one at the top, middle and bottom. You can use our [stainless steel](#) sheet fixings and bonded washers for this.



6. Once joiner has been clicked together, fit the supplied 50mm end cap over the end of the joiner. This can be fixed with a single screw through the top. OR a long rivet. If you are using our joiner on both outside edges you will need to slide the supplied edge strip into the outside edge of the joiner before putting the cap on.

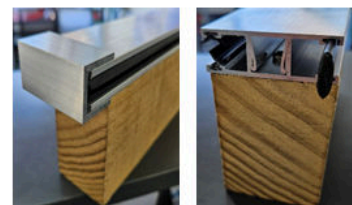

7. Once all your sheet is installed, remove the protection film on both sides if not already done. This film will either be a paper or plastic film. **If using Twin wall, this is when you will apply the polycarbonate end cap.** Please note that you should not leave this protection film on the sheet sitting in the sun for too long. If it is a paper film, do not get this wet as it is very hard to remove if wet.

Additional notes:
If you are fixing sheet directly to the rafters OR purlins please ensure that you [pre drill a](#) 8mm to 10mm expansion hole through your sheet. This allows the sheet to expand and contract around the fixing. The best way to do this is with a step drill bit and our [stainless steel](#) sheet fixings with bonded washers.



Colours depicted in this brochure are representations offered only as a guide and should not form the basis of a colour selection. Slight colour variation may occur between production runs. Transmitted light and colour may vary in intensity depending on weather conditions. The information contained in this brochure is to the best of our knowledge accurate, but all recommendations are made without any warranty whatsoever, since the conditions of use are beyond our control. This brochure cancels and supersedes all previous published information. The company reserves the right to alter and revise, without notice, the information contained herein. © Registered trademark of Alsynite New Zealand Ltd. Laserlite® is a registered trademark of Mulford International.

Supreme Plastic Roofing

Unit 1, 29-31 Princes Street, Onehunga, Auckland Ph: 09 636 0949 | Fax: 09 636 0940 | Email: info@supremeplastics.co.nz